



AirLaser

**No longer failures
due to weather conditions!**



- ✓ Free space optic system for hop lengths up to 2000 m;
- ✓ Designed for full duplex Fast Ethernet with 100 Mbps and Gigabit Ethernet with 1000 Mbps;
- ✓ Weather independent! 99.99 % availability guaranteed by the integrated licence-free radio link as backup. Permanent monitoring of the optical link enables an automatic switching;
- ✓ Extensive management via SNMP agent or web-based with standard web browsers;
- ✓ Alarms can be transmitted to a maximum of four email addresses;
- ✓ Redundant power supply with 230 or 115 VAC and additional 48 VDC as standard;
- ✓ A complete new and modular concept turns out to highest investment protection for the user.

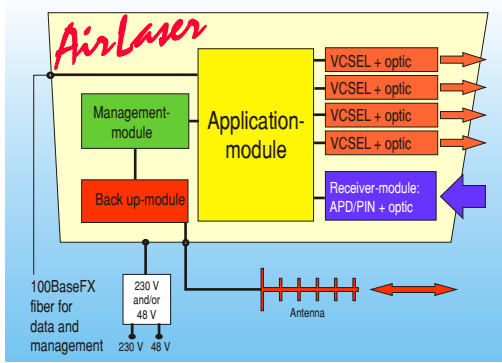

Modularity

AirLaser systems base on a complete modular concept and have very compact dimensions. Around the common optical devices the application-, the management-, and the microwave-backup-modules are arranged. The application-module offers the user interfaces, the interfaces for the receiver and transmission unit as well as the interfaces for the additional modules.



Backup

Using the AirLaser IP100 failures due to weather conditions will not occur anymore because of the optional backup, that may be integrated directly into the system. This backup, based on a licence free radio system, can easily be appended to the management module. Previous customer solutions with expensive routers or complex configurations are no longer necessary. Also the antennas can be easily installed by the user.

Management

The module provides an SNMP agent as well as an integrated webserver for a web-based management. Configuration and controlling takes place via an existing SNMP compatible network management software or a common web browser. Administrators monitor both locations and the actual status of the link within only one overview.



Technical data	AirLaser IP100	AirLaser IP1000	Unit
Transmission			
Distance, max.	Up to 2000	Up to 800	m
Data rate	125	1250	Mbps
Back-up data rate	up to 4.5	-	Mbps
Application	Fast Ethernet IEEE 802.3u, 802.1q	Gigabit Ethernet IEEE802.3z	-
Air interface			
Transmitter	2/4 VCSEL laser diodes	4 VCSEL laser diodes	-
Power	2/4 x 7.5	4 x 7.5	mW
Aperture	2/4 x 28.25	4 x 28.25	cm ²
Laser class	1 M (eyesafe)		
Divergence	2		mrad
Dynamic	36	30	dB
Receiver	PIN/APD	APD	
Sensitivity	-33 / -43	-33	dBm
Wavelength	850		nm
Interfaces			
Standard	10/100BaseT or 100BaseFX	1000BaseSX/LX	-
Wavelength	1300	SX: 850, LX: 1300	nm
Fiber	standard: multimode, optional: singlemode		
Connector	standard: RJ45 or duplex SC, others via hybrid connectors		
Power supply	230/115 VAC or/and 48 VDC		V
Power consumption	27	35	VA
Additional data			
Operational temperature	-25 ... +50 -13 ... +122	-25 ... +50 -13 ... +122	degrees C degrees F
Weight (w/o holder)	7.5	7.7	kg
Dimensions (w/o antennas)	240 x 190 x 460 (width, height, depth)		mm

CBL GmbH

Darmstaedter Str. 81
D-64839 Muenster
Tel. +49 6071 / 303 - 0
Fax +49 6071 / 303 - 499
<http://www.cbl.de>
email: info@cbl.de

CBL s.r.o.

Strossova 131
CZ-53002 Pardubice
Tel. +420 466 613 777
Fax +420 466 613 407
<http://www.cbl.cz>
email: cbl@cbl.cz